

AV5100

Arecont Vision
megapixel technology...
beyond imagination

5 Megapixel JPEG IP MegaVideo® camera

AV5100M (Color) AV5100DN (Day/Night) AV5100-AI (Color Auto-Iris)

MegaVideo® Series

AV5100 Series network camera delivers full motion progressive scan 2592 x 1944 video at 9 fps featuring massively-parallel MegaVideo® image processing architecture capable of sustaining over 6 billion operations per second.

Arecont Vision Advantages:

Superior Low Light Performance

- 1/2.5" CMOS Sensor

Unparalleled High Definition Resolution - 2592x1944

- Fifteen times the resolution of IP VGA or analog cameras

Fastest MegaPixel Image Rates

- Up to 9fps in 5 megapixel mode

Forensic Zooming

- Zoom live or after-event while recording full field of view in HD ... replace PTZ devices

Reduced Overall System Cost

- Less cameras to install, less wiring, no external power (POE), less NVR licensing fees

Cost Efficiency

- Comparable cost to IP VGA & analog cameras

Full or 1/4 Resolution

- Can be selected for either live viewing or archiving purposes

Other key features:

- Simultaneous full field of view and Region-of-Interest (ROI)
- Image cropping allows streaming of full density partial images
- On-camera motion detection
- Mechanical IR Cut Filter (DN Version) and more

H.264 versions are also available

Learn more about our products at www.arecontvision.com

www.arecontvision.com avsales@arecontvision.com 818.937.0700 877.CAMERA.8

Model Numbers:

AV5100M - Color

AV5100-AI - Color Auto-Iris

AV5100DN - Day/Night

Imaging

- 5 megapixel CMOS image sensor
- 2592(H) x 1944(V) pixel array
- 1/2.5" optical format optical format
- 2.2 µm pixel pitch
- Bayer mosaic RGB filter
- Minimum illumination of:
 - Color: 0.3 Lux @ F1.4
 - Day/Night: 0 Lux, IR sensitive
- Dynamic range 70.1dB
- Maximum SNR 44.1 dB

Full Field of View (FOV) Resolutions

- 2592(H)x1944(V) 5 megapixel
- 1296(H)x968(V) 1/4 resolution

Cropped Field of View Resolution

- 2560x1600 WQXGA
- 2048x1536 3MP
- 1920x1200 WUXGA
- 1920x1080 HDTV-1080p
- 1600x1200 2 MP
- 1280x1024 1.3 MP
- 1280x720 HDTV-720p
- 1024x768 XGA
- 800x600 SVGA
- 704x570 PAL
- 704x480 NTSC
- 640x480 VGA
- 352x288 CIF
- 320x240 SIF

Data Transmission

- Video frame rate up to:
 - 9fps @ 2592x1944
 - 12fps @ 2560x1600
 - 15fps @ 2048x1536
 - 24fps @ 1600x1200
 - 30fps @ 1280x1024
- Motion JPEG with 21 levels of quality
- TFTP and HTTP image transmission protocols
- 100Base-T Ethernet Network Interface
- Data rate up to 55Mbps
- Multi-streaming: 8 non-identical streams

Programmability

- Auto Exposure (AE) and Gain Control (AGC) >120dB
- On-camera motion detection with 64 detection zones
- Auto backlight compensation
- Auto multi-matrix white balance
- 50/60Hz selectable flicker control
- Electronic pan, tilt, zoom (PTZ)
- Electronic image rotation - 180° flip
- Resolution windowing down to 32x32 pixels window
- Programmable shutter to minimize motion blurring for low-light mode
- Moonlight™ mode - extended exposure and proprietary noise cancellation
- Programmable resolution, brightness, saturation, gamma, sharpness, tint
- Picture-in-Picture: simultaneous delivery of full field of view and zoomed images
- Bandwidth & storage savings by running at 1/4 resolution

Electrical

- General purpose opto-coupled input and output
- Power over Ethernet (PoE): PoE 802.3af
- DC input: auxiliary 15V-48V DC
- Power consumption 3 Watts maximum
- Optional DC AI connection (AV5100 - AI)

Regulatory Approvals

- FCC, CE and RoHS compliant

Environmental

- Operating temperature 0°C (32 °F) to +50°C (122 °F)
- Storage temperature -20°C (-4 °F) to +60°C (140 °F)
- Humidity 0% to 90% (non condensing)

Mechanical

- 3"W (76 mm) x 2.5"H (63.5 mm) x 2.25"D (57mm) (w/o lens)
- 8.6 oz (243 grams) (w/o lens)
- C/CS lens mount

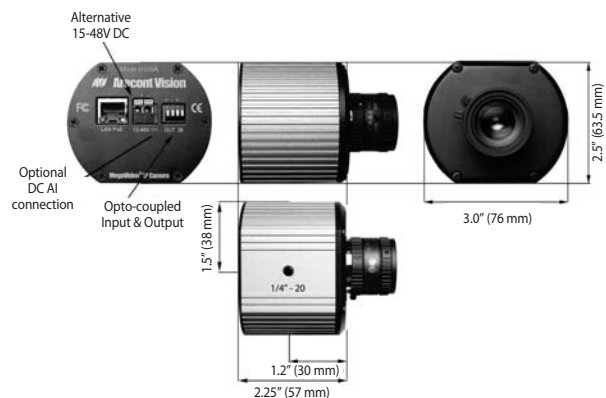

H.264 versions available:

(see H.264 specification sheets for more information)
 AV5105
 AV5105 - AI
 AV5105DN

Housing Accessories:

Dome 4-I - Indoor 4" Vandal Dome
 Dome 4-O - Outdoor 4" Vandal Dome
 Dome 5-I - Indoor 5" Recessed Dome
 HSG1-O-W - Outdoor Environmental Housing w/Heater/Blower

Lenses:

MPL4-10
 MPL8-16
 MPL4.0
 MPL6.0
 MPL8.0
 LENS4-13
 LENS4-10AI

* Other megapixel lenses are also available with Arecont Vision's housing options.